

ebm-papst Mulfingen GmbH & Co. KG

Bachmühle 2 · D-74673 Mulfingen

Phone +49 7938 81-0

Fax +49 7938 81-110

info1@de.ebmpapst.com

www.ebmpapst.com

Limited partnership · Headquarters Mulfingen

Amtsgericht (court of registration) Stuttgart · HRA 590344

General partner Elektrobau Mulfingen GmbH · Headquarters Mulfingen

Amtsgericht (court of registration) Stuttgart · HRB 590142

Nominal data

Type	W1G130-AA25-11		
Motor	M1G055-AI		
Phase		1~	1~
Nominal voltage	VAC	230	230
Frequency	Hz	50/60	50/60
Method of obtaining data		ml	ml
Speed (rpm)	min ⁻¹	2800	3200
Power consumption	W		24
Current draw	A		0.19
Max. back pressure	Pa		90
Max. back pressure	in. wg		0.36
Min. ambient temperature	°C	-30	-30
Max. ambient temperature	°C	70	60

ml = Max. load · me = Max. efficiency · fa = Free air · cs = Customer specification · ce = Customer equipment
 Subject to change

Technical description

Weight	0.8 kg
Size	130 mm
Motor size	55
Impeller material	PA plastic
Fan housing material	PP plastic
Number of blades	7
Airflow direction	V
Direction of rotation	Counterclockwise, viewed toward rotor
Degree of protection	IP55
Insulation class	"B"
Moisture (F) / Environmental (H) protection class	H1+
Max. permitted ambient temp. for motor (transport/storage)	+ 80 °C
Min. permitted ambient temp. for motor (transport/storage)	- 40 °C
Installation position	Any
Condensation drainage holes	None
Mode	S1
Motor bearing	Ball bearing
Technical features	<ul style="list-style-type: none"> - Speed selection max./min. - Soft start - Thermal overload protection for motor
Speed levels	2
EMC immunity to interference	According to EN 61000-6-2 (industrial environment)
EMC circuit feedback	According to EN 61000-3-2/3
EMC interference emission	According to EN 61000-6-3 (household environment)
Motor protection	Temperature limiter manual reset
With cable	Lateral
Protection class	II
Conformity with standards	EN 60335-1; EN 60335-2-24; EN 60335-2-80; EN 60335-2-89; CE
Approval	VDE

Product drawing

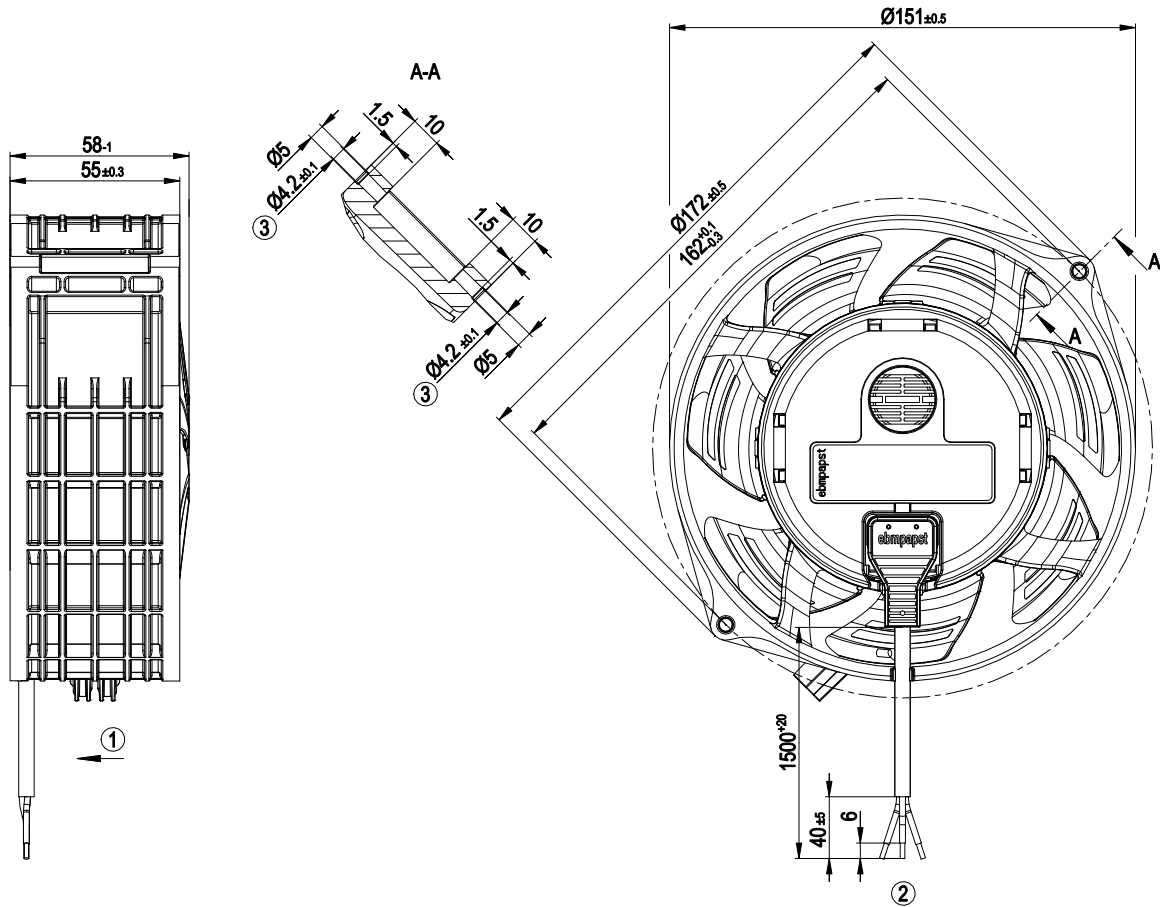

- | | |
|---|---|
| 1 | Direction of air flow "V" |
| 2 | Cable PVC 3G AWG20, 3x crimped splices |
| 3 | Preferably 2x Remform screws WN-156-2 5.0x16 Torx galvanized from Arnold should be used.
Alternatively, 2x metric M4 screws fastened with nuts |

Connection diagram

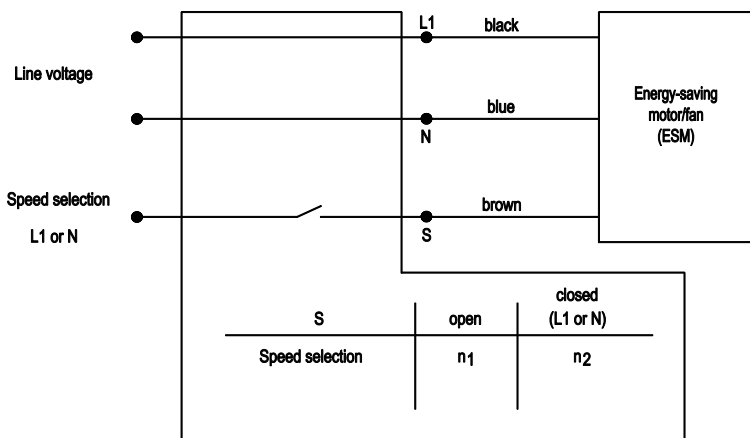

Curves: Air performance 50 Hz

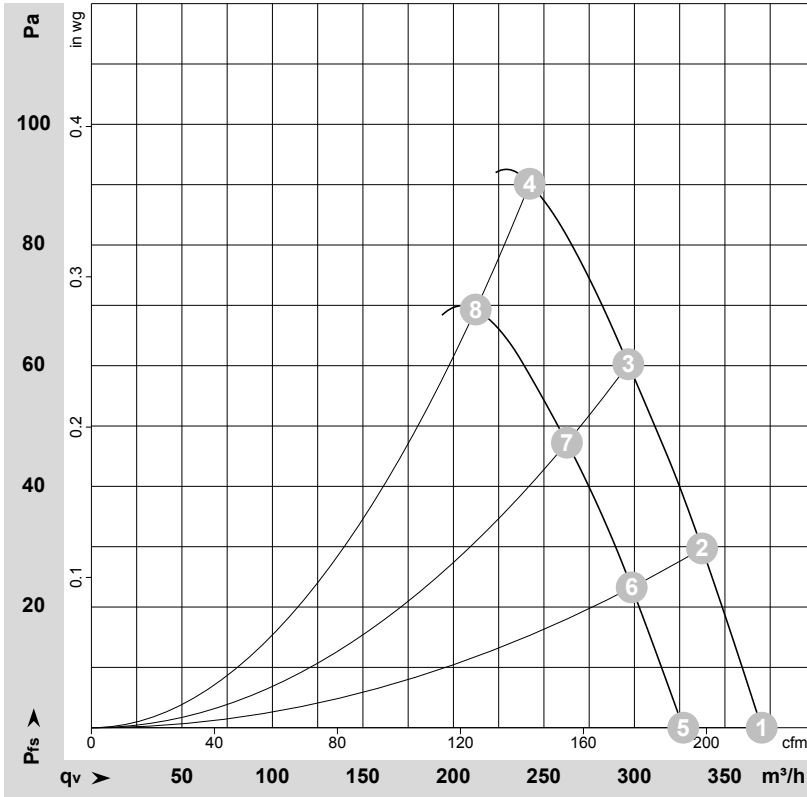

$\rho = 1.177 \text{ kg/m}^3 \pm 2 \%$

Measurement: LU-139739-1
 Measurement: LU-140010-1

Air performance measured according to ISO 5801 installation category A. For detailed information on the measurement setup, contact ebm-papst. Intake sound level: Sound power level according to ISO 13347 / sound pressure level measured at 1 m distance from fan axis. The values given are valid under the specified measuring conditions and may vary due to conditions of installation. For deviations from the standard configuration, the parameters have to be checked on the installed unit.

Measured values

	U	f	n	P _{ed}	I	LpA _{in}	LwA _{in}	q _v	P _{fs}	q _v	P _{fs}
	V	Hz	min ⁻¹	W	A	dB(A)	dB(A)	m ³ /h	Pa	cfm	in. wg
1	230	50	3200	23	0.19	55	63	370	0	220	0.00
2	230	50	3200	24	0.19	53	61	335	30	200	0.12
3	230	50	3200	24	0.19	51	60	295	60	175	0.24
4	230	50	3200	24	0.19	54	63	240	90	140	0.36
5	230	50	2800	16	0.13	51	60	325	0	190	0.00
6	230	50	2800	16	0.13	50	58	300	24	175	0.10
7	230	50	2800	16	0.13	48	57	265	47	155	0.19
8	230	50	2800	16	0.13	53	61	210	70	125	0.28

U = Voltage · f = Frequency · n = Speed (rpm) · P_{ed} = Power consumption · I = Current draw · LpA_{in} = Sound pressure level intake side · LwA_{in} = Sound power level intake side
 q_v = Air flow · P_{fs} = Pressure increase

