

ebm-papst Mulfingen GmbH & Co. KG

Bachmühle 2 · D-74673 Mulfingen

Phone +49 7938 81-0

Fax +49 7938 81-110

info1@de.ebmpapst.com

www.ebmpapst.com

Limited partnership · Headquarters Mulfingen

Amtsgericht (court of registration) Stuttgart · HRA 590344

General partner Elektrobau Mulfingen GmbH · Headquarters Mulfingen

Amtsgericht (court of registration) Stuttgart · HRB 590142

Nominal data

Type	W2S130-AA03-63		
Motor	M2S052-CA		
Phase		1~	1~
Nominal voltage	VAC	230	230
Frequency	Hz	50	60
Method of obtaining data		fa	fa
Valid for approval/standard		CE	CE
Speed (rpm)	min ⁻¹	2800	3250
Power consumption	W	45	39
Current draw	A	0.31	0.25
Max. back pressure	Pa	80	120
Max. back pressure	in. wg	0.32	0.48
Min. ambient temperature	°C	-25	-25
Max. ambient temperature	°C	50	70
Starting current	A	0.45	0.40

ml = Max. load · me = Max. efficiency · fa = Free air · cs = Customer specification · ce = Customer equipment
 Subject to change

Technical description

Weight	1.1 kg
Size	130 mm
Motor size	52
Rotor surface	Rotor open, painted black
Blade material	Sheet steel, painted black
Fan housing material	Die-cast aluminum, painted black
Number of blades	7
Airflow direction	V
Direction of rotation	Counterclockwise, viewed toward rotor
Degree of protection	IP20
Insulation class	"B"
Moisture (F) / Environmental (H) protection class	H0+
Max. permitted ambient temp. for motor (transport/storage)	+ 80 °C
Min. permitted ambient temp. for motor (transport/storage)	- 40 °C
Installation position	Any
Condensation drainage holes	None, open rotor
Mode	S1
Motor bearing	Ball bearing
Touch current according to IEC 60990 (measuring circuit Fig. 4, TN system)	< 0.75 mA
Motor protection	Thermal overload protector (TOP) internally connected
Protection class	I (with customer connection of protective earth)
Conformity with standards	EN 60335-1; CE

Product drawing

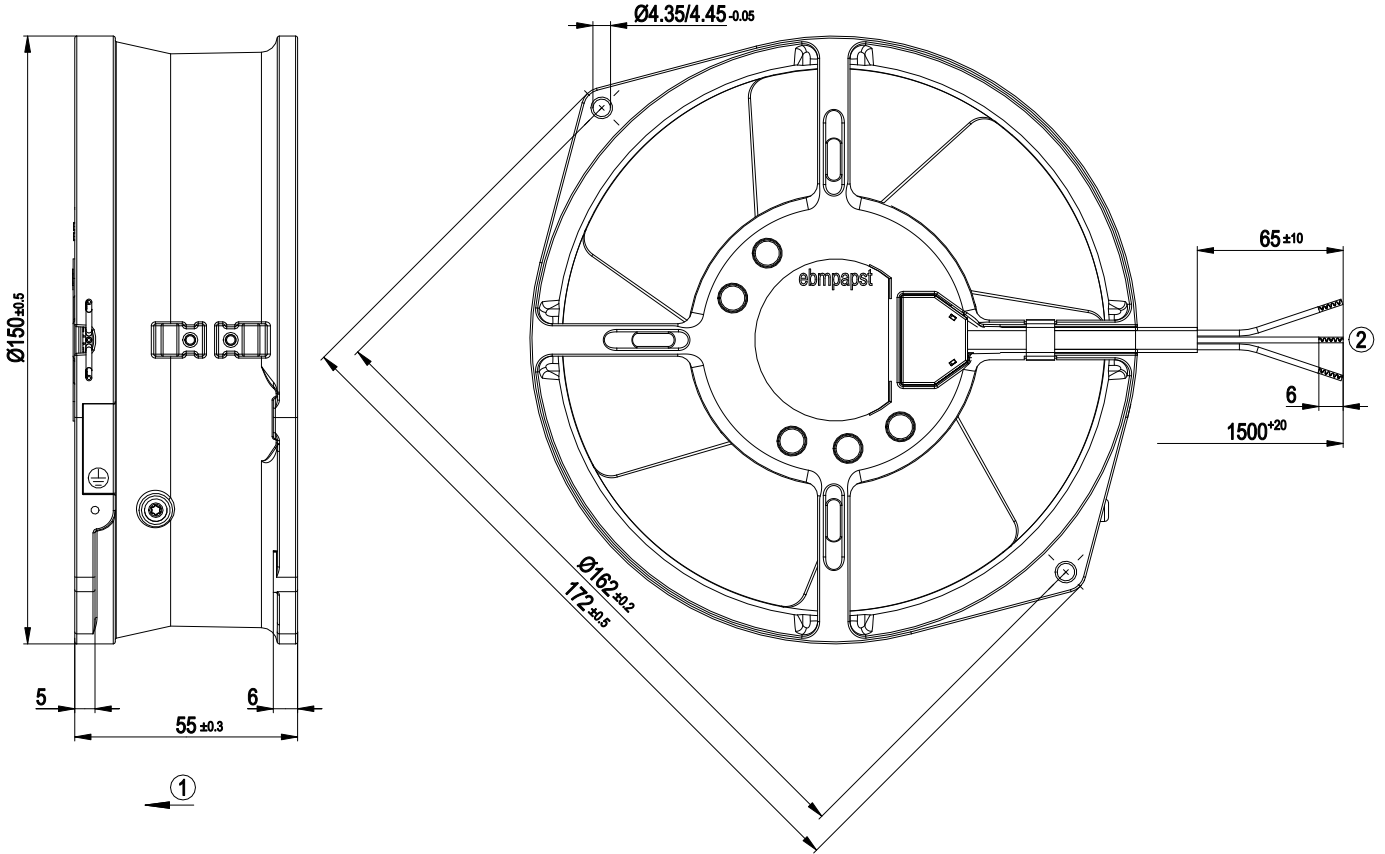

1	Direction of air flow "V"
2	Cable PVC 3G 0.5 mm ² , 3x crimped splices

Connection diagram

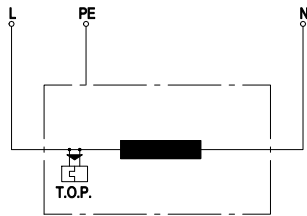

L	= blue
PE	= green/yellow
N	= brown
TOP	= thermal overload protector

Curves: Air performance 50 Hz

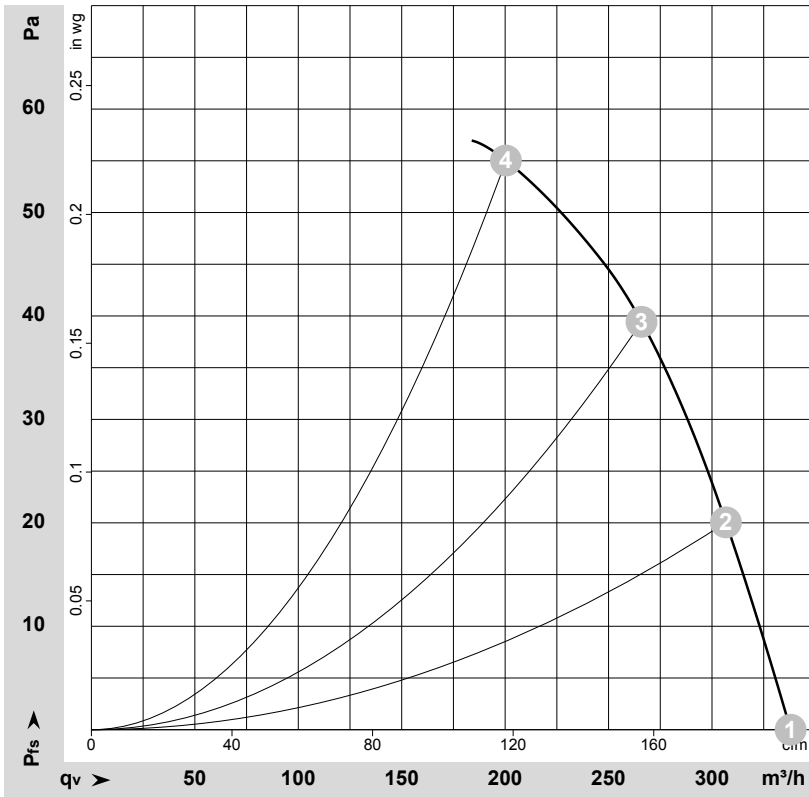

$\rho = 1.15 \text{ kg/m}^3 \pm 2 \%$

Measurement: LU-58475-1

Air performance measured according to ISO 5801 installation category A. For detailed information on the measurement setup, contact ebm-papst. Intake sound level: Sound power level according to ISO 13347 / sound pressure level measured at 1 m distance from fan axis. The values given are valid under the specified measuring conditions and may vary due to conditions of installation. For deviations from the standard configuration, the parameters have to be checked on the installed unit.

Measured values

	U	f	n	P _e	I	q _v	p _{fs}	q _v	p _{fs}
	V	Hz	min ⁻¹	W	A	m ³ /h	Pa	cfm	in. wg
1	230	50	2800	45	0.31	340	0	200	0.00
2	230	50	2795	45	0.31	305	20	180	0.08
3	230	50	2780	46	0.31	265	40	155	0.16
4	230	50	2780	46	0.31	200	55	120	0.22

U = Voltage · f = Frequency · n = Speed (rpm) · P_e = Power consumption · I = Current draw · q_v = Air flow · p_{fs} = Pressure increase

Curves: Air performance 60 Hz

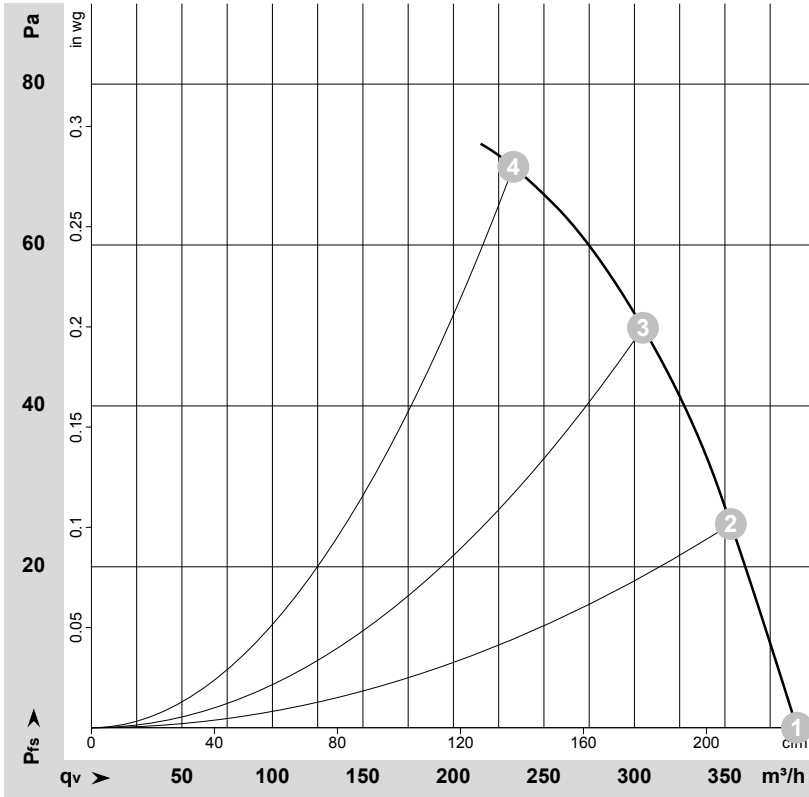

$\rho = 1.15 \text{ kg/m}^3 \pm 2 \%$

Measurement: LU-58476-1

Air performance measured according to ISO 5801 installation category A. For detailed information on the measurement setup, contact ebm-papst. Intake sound level: Sound power level according to ISO 13347 / sound pressure level measured at 1 m distance from fan axis. The values given are valid under the specified measuring conditions and may vary due to conditions of installation. For deviations from the standard configuration, the parameters have to be checked on the installed unit.

Measured values

	U	f	n	P _e	I	q _v	p _{fs}	q _v	p _{fs}
	V	Hz	min ⁻¹	W	A	m ³ /h	Pa	cfm	in. wg
1	230	60	3250	39	0.25	390	0	230	0.00
2	230	60	3200	42	0.25	355	25	210	0.10
3	230	60	3165	43	0.26	305	50	180	0.20
4	230	60	3145	44	0.26	235	70	135	0.28

U = Voltage · f = Frequency · n = Speed (rpm) · P_e = Power consumption · I = Current draw · q_v = Air flow · p_{fs} = Pressure increase

